

Natura is a bleached liquid packaging board with a three-layer fibre construction, with two outer layers made of bleached sulphate pulp and a middle layer made of CTMP (chemi-thermomechanical pulp).

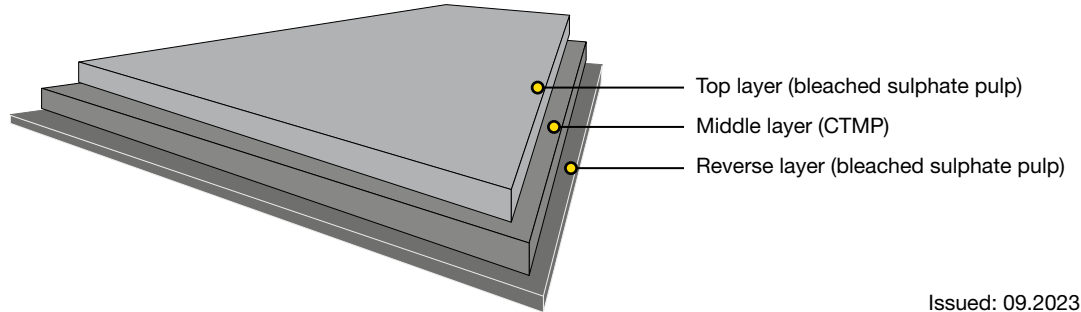

Issued: 09.2023  
Cancels: 07.2023

### Technical specification from Imatra BM4; New Natura (KP500)

Property / Unit							Standards
Grammage, g/m <sup>2</sup>	220	233	257	273	288	350	ISO 536
Thickness, µm	370	402	450	465	505	570	ISO 534
Density, kg/m <sup>3</sup>	603	580	571	587	570	614	
Bending resistance (L&W 15°) MD, mN	317	415	580	635	760	1080	ISO 2493
Bending resistance (L&W 15°) CD, mN	120	162	223	242	303	410	
Bending resistance (L&W 15°) GM, mN	195	260	360	392	480	665	
Bending moment (Taber 15°) MD, mNm	15.3	20.0	28.0	30.7	36.7	52.2	
Bending moment (Taber 15°) CD, mNm	5.8	7.8	10.8	11.7	14.6	19.8	
Bending moment (Taber 15°) GM, mNm	9.4	12.6	17.4	18.9	23.2	32.1	
Moisture, %	6.5	6.5	6.5	6.5	6.5	6.5	ISO 287
Brightness (D65/10°), %, Top	78	78	78	78	78	79	ISO 2470
Roughness (Bendtsen), ml/min, Top	350	350	350	350	350	400	ISO 8791-2
Packaging size suggestion, ml	<500	<500	1000	1000	1500	2000	



# Natura™ Board

## Bleached liquid packaging board

### Certificates

- Quality management ISO 9001
- Environmental management ISO 14001
- Product safety FSSC 22000
- Occupational health and safety ISO 45001
- Energy management ISO 50001



FSC and PEFC certified board available upon request.



Paperboard can be recycled

### Key characteristics and main enduses

Natura offers the best in product protection, in printing, converting and filling performance, and in economy and sustainability. Like all Stora Enso liquid packaging board qualities, it has an exceptionally high standard of odour and taint neutrality, which makes it especially suitable for packaging sensitive food products and keeping them fresh and hygienic, unchanged and untainted for their entire lifetime. When combined with an appropriate barrier, the product range serves a wide array of packaging applications, such as milk, juice, soups, spices, water and yoghurt, as well as various high-volume non-food products, such as liquid detergents and fabric softeners.

### Storage recommendations

For optimal printing results, the moisture proof wrapping should not be removed until the board has reached the temperature of the press room.

Pallet/Reel Weight (kg)	Difference in temperature between board and press room (press room temp, approx. 20°C)		
	10°C	20°C	30°C
400 kg	2 days	2 days	3 days
800 kg	2 days	3 days	4 days
1200 kg	2 days	4 days	5 days

The product properties, according to the specifications, are guaranteed for 12 months after the production date. In order to ensure product safety, the product must be well wrapped and stored indoors, sheltered from rain and snow. The recommended storage conditions are 50-55% relative humidity and 20-23°C.