

Cupforma Special Barr™

Pigment coated cup board with high barrier EB31

Cupforma Special Barr is a board with a three layer fibre construction including CTMP (chemi-thermomechanical pulp) in the middle layer and a fully pigment coated top side. The board has a multilayer high-barrier coating on its reverse side.

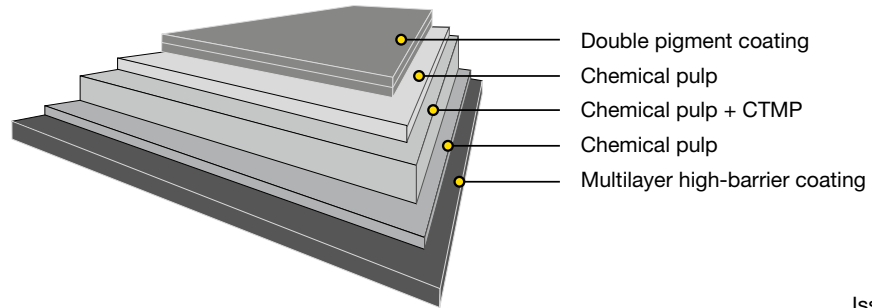

Issued: 05.2024
Cancels: 11.2020

Technical specification

Property / Unit	Tolerance	195+EB31	210+EB31	230+EB31	255+EB31	270+EB31	295+EB31	320+EB31	350+EB31	Standard
Polymer coated board:										
Grammage, g/m ²	±7%	226	241	261	286	301	326	351	381	ISO 536
PE reverse, g/m ²	±4	31	31	31	31	31	31	31	31	Mill method
Thickness, µm	±9%	286	306	346	376	416	456	496	536	ISO 534
Baseboard:										
Grammage, g/m ²	±6%	195	210	230	255	270	295	320	350	ISO 536
Thickness, µm	±8%	260	280	320	350	390	430	470	510	ISO 534
Bending resistance L&W 15° MD, mN	min -20%	120	155	215	270	360	475	600	760	ISO 2493-1
Bending resistance L&W 15° CD, mN	min -20%	55	70	95	125	170	210	270	340	
Moisture %	min 5.0%	6.5	6.5	6.5	6.5	6.5	6.5	6.5	6.5	ISO 287
Surface Smoothness, PPS 10, µm, Top	max 1.7	1.2	1.2	1.2	1.2	1.2	1.2	1.2	1.2	ISO 8791-4
Brightness D65/10°, Top		85	85	85	85	85	85	85	85	ISO 2470-2
Surface Smoothness, Bendtsen, ml/min	max 130	40	40	40	40	50	50	50	50	ISO 8791-2
Stretch CD, %		6.0	6.0	6.0	6.0	6.0	6.0	6.0	6.0	ISO 1924-3

Also available with PE-coating on topside



Cupforma Special Barr™

Pigment coated cup board with high barrier EB31

Certificates

- Quality management ISO 9001
- Environmental management ISO 14001
- Product safety FSSC 22000
- Occupational health and safety ISO 45001
- Energy management ISO 50001



FSC and PEFC certified board available upon request.

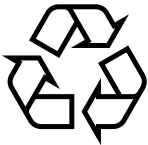

Paperboard can be recycled

Key characteristics and main enduses

Cupforma Special Barr is designed especially for cups and for very high requirements on printing. It is food-safe and the baseboard is made with renewable materials. Cupforma Special Barr works smoothly and consistently in the cup converting. It is also economical as the board's structure provides the required stiffness; resulting in light, yet functional cups. The fully pigment coated top side is very smooth, which ensures high-quality print results in flexographic, offset, and digital printing to showcase brands. Multilayer Barr coating of PE and EVOH gives excellent protection against moisture, oxygen and grease. Cupforma Special Barr can be used for extended shelf life products like snacks or other dry food.

Printing and finishing techniques

The product can be used for different printing techniques such as offset, flexo and digital printing. It is important to check possible limitations of the printing and converting equipment and ensure that the basis weight of the board fits the tooling to be used. Since a wide variety of digital printing equipment is available in the market, it is important that a new commercial digital print job is always preceded by a trial run, including all required printing and converting process phases.

Storage recommendations

For optimal printing results, the moisture proof wrapping should not be removed until the board has reached the temperature of the press room.

Pallet/Reel Weight (kg)	Difference in temperature between board and press room (press room temp. approx. 20°C)		
	10°C	20°C	30°C
400 kg	2 days	2 days	3 days
800 kg	2 days	3 days	4 days
1200 kg	2 days	4 days	5 days

The product properties, according to the specifications, are guaranteed for 12 months after the production date. In order to ensure product safety, the product must be well wrapped and stored indoors, sheltered from rain and snow. The recommended storage conditions are 50–55% relative humidity and 20–23° C.

For the Corona treatment, we recommend using the board within 12 months of the production date; after this period, the treatment level should be tested before printing or gluing.